

A NEW PARAMETER TO PREDICT CAVITATION EROSION

H. Soyama, H. Kumano and M. Saka
Tohoku University, Sendai 980-8579, Japan

Abstract

In order to avoid or predict cavitation erosion, it is necessary to know resistance of materials against to cavitation impacts. The cavitation impacts, which are larger than certain threshold level, only affect cavitation erosion of materials. In the present paper, existence of the threshold level was revealed experimentally. The threshold level of material is a new parameter to predict the cavitation erosion. Erosion rates for several materials were clarified by using a cavitating jet erosion test, which was new ASTM standard ASTM G134. The cavitation impacts induced by the cavitating jet were measured by means of a special made PVDF transducer, and energy of cavitation impacts was calculated. The threshold levels for several materials were revealed from the relation between the erosion rate and the energy of the cavitation impacts. A method to predict the cavitation erosion quantitatively from the threshold level of material and the measurement of cavitation impacts was proposed.

1 Introduction

In order to predict cavitation erosion, it is most important to clear a relation between cavitation impacts and resistance of material. A new parameter in the relation between the impact and the resistance was proposed in the present paper. It is "threshold level" of materials to the cavitation impacts. The threshold level means that the cavitation impacts which are larger than the threshold level may affect the material. The existence of the threshold level was revealed experimentally in this paper.

Weak cavitation impacts, which don't produce elastic or plastic deformation, should not take part in cavitation erosion. On the other hand, strong cavitation impacts take place the plastic deformation and then produce the damage with mass loss. Lecoffre (1995) also proposed similar idea of threshold level of materials. However, a method to measure the threshold level was not revealed.

The impact resulted from collapse of cavitation bubble has very high intensity such as 10 GPa (Jones and Edwards 1960), and a rising time of the impact is a few microsecond. The affected area of the impact is very limited area in micrometer order. Many researchers have been tried to predict erosion rate by measurement of plastic deformation erosion pits at early stage of the exposure to cavitation. However, the pit size does not reveal the intensity at physical unit such as force or pressure. Okada et al. investigated the cavitation intensity using a piezo ceramics (1984 and 1994). Momma and Lichtarowicz (1994), Hoam (1994) and Arndt et al. (1995) measured the cavitation intensity using piezo electric polymer PVDF (Polyvinylidene Flouride). The characteristic of PVDF film reveals a high natural frequency such as 10 MHz of 110 μm thickness, a high piezoelectric constant -3.39×10^{-5} (V/m)/Pa and a high S/N ratio. Then an amplifier, a noise filter and a peak hold circuit are not required. As the PVDF can be easy to cut and vent, the PVDF film can be applied to fit in hydraulic machinery. Soyama et al. (1998) developed the special made transducer using PVDF film, and the cavitation intensity around cavitating jet, which is used for the cavitation erosion test, has been investigated.

The great advantage of the erosion test by using cavitating jet (ASTM G134-95) is that the cavitation intensity can be changed by the hydrodynamic parameter, such as upstream pressure and downstream pressure. Thus, the cavitating jet apparatus can simulate several cavitating condition. If a relation between the cavitation intensity of the cavitating jet and the erosion rate of materials were investigated precisely, the key parameter to predict cavitation erosion rate can be clarified.

In the present paper, the intensity of the cavitation impacts induced by a cavitating jet was measured by using a PVDF transducer, and the erosion test was carried out for several cavitating conditions by using a cavitating jet apparatus. A new parameter, i.e., threshold level, to predict cavitation erosion was proposed, as a result from the

relation between the energy of impact and the erosion rate. It is noted that this is first paper to show the individual threshold level of materials for cavitation erosion. The predict method for cavitation erosion arisen in hydraulic machineries by using a cavitating jet apparatus and PVDF transducer was also proposed.

2 Experimental Facilities and Procedures

Cavitating jet apparatus

Figure 1 shows a schematic diagram of a cavitating jet loop. The test water was injected into the water filled test section through a nozzle by a plunger pump, whose maximum capacity is 21 MPa in the pressure and $2.17 \times 10^{-4} \text{ m}^3/\text{s}$. The nozzle diameter was 0.4 mm and the discharge coefficient of the nozzle was 0.64. The same nozzle was used for the erosion test and the cavitation impact measurement. The cavitating condition was controlled by the upstream pressure and the downstream pressure across the nozzle.

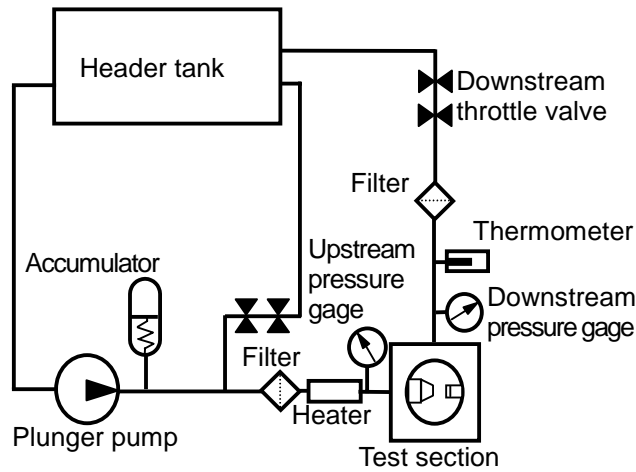

Figure 1: Cavitating jet apparatus

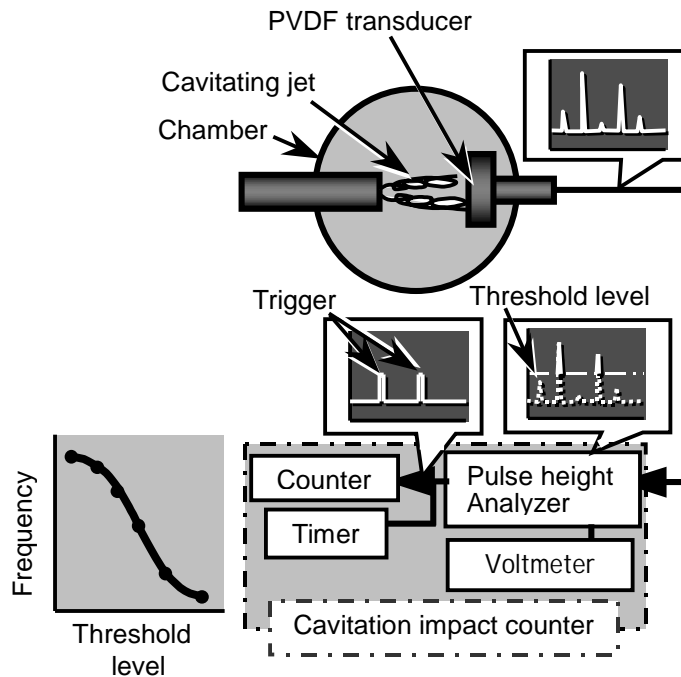

Figure 2: Diagram of cavitation impact measurement

Cavitation impact measurement

A special made transducer was developed by Soyama et al. (1998). A PVDF film was used as sensitive material. The PVDF transducer was calibrated by a pencil lead breaking method. The detail of the transducer and calibration method were in the reference (Soyama et al., 1998).

Figure 2 shows diagram of the analog pulse height analyzing system. The impact duration of the cavitation is a few micro second and it occurs sporadically. For example a huge impact, whose pulse duration was about 5 μ s, takes place once per minutes. If the digital system was used, the huge memory size was required. This is the reason why the analog circuit was used. The signal was come from the PVDF transducer, the number of the pulse, whose pulse height was larger than the threshold level, was counted by a counter. The pulse height distribution was obtained by changing the threshold level at same cavitating condition. The measuring time was changed from 5 seconds to 1 minute considering the threshold level.

Energy E of cavitation impacts related to cavitation erosion was calculated following procedure. Energy of individual impact E_i was defined by acoustic energy I_i , impact duration τ_i and affective area A_i of each impact as follows;

$$E_i = I_i \tau_i A_i \quad (1)$$

According to spherical propagation of acoustic pulse, the acoustic energy I_i was defined by following Eq. (2);

$$I_i = \frac{P_i^2}{2 \rho C} \quad (2)$$

where P_i , ρ and C are acoustic pressure, density and acoustic speed, respectively. Individual impact force F_i can be measured by PVDF transducer (Soyama et al., 1998). The force was the product of the pressure P_i and the area A_i as follows;

$$F_i = P_i A_i \quad (3)$$

The energy of the individual impact was revealed by the following Eq. (4), by putting Eqs. (2) and (3) into Eq. (1).

$$E_i = \frac{F_i P_i \tau_i}{2 \rho C} \quad (4)$$

here, the pressure P_i and the duration τ_i were unknown parameter. If the pressure P_i was proportional to the force F_i and the duration τ_i was constant, the energy was proportional to the square of the force as Eq. (5).

$$E_i \propto F_i^2 \quad (5)$$

The force F_i was measured by the PVDF transducer. The energy E of the cavitation impact related to the cavitation erosion will be summation of the square of the force F_i , which is larger than the threshold level F_{th} .

$$E = \sum E_i \propto \sum_{F_i} F_i^2 \quad (6)$$

Soyama et al. (1998) have already shown that the energy measured by PVDF transducer was proportional to erosion rate.

Erosion test

Tested materials were pure aluminum (JIS A1050), pure copper (JIS C1100), acryl resin and ceramics. Table 1 shows the test conditions for the erosion test. The cavitation impact measurement was also carried out at the same cavitating condition. Cavitation number σ , which is main parameter of cavitating flow, was defined by the upstream pressure p_1 , the downstream pressure p_2 and vapor pressure p_v of test water as follows;

$$\sigma = \frac{p_2 - p_v}{p_1 - p_2} \cong \frac{p_2}{p_1} \quad (7)$$

Table 1 Test condition

Cavitation number σ	Upstream pressure p_1 MPa	Downstream pressure p_2 MPa	Optimum standoff distance s mm
0.014	15	0.21	19
0.014	20	0.28	19
0.025	20	0.50	14

The cavitation number was simplified as Eq. (7), because of $p_1 \gg p_2 \gg p_v$. The erosion test was carried out changing with the standoff distance by using brass specimen, and the optimum standoff distance was defined the standoff distance where the erosion rate had maximum value.

3 Results

Energy of cavitation impact force

Figure 3 illustrates a pulse height distribution, which shows a relation between the threshold level F_{th} and the energy of the cavitation impact that were larger than the threshold level. At the constant cavitation number, when the upstream pressure was increased, the energy of the impact was increased for all range of threshold level. On the other hand, at the different cavitation number, even though the upstream pressure was constant, the distribution was different. It is note that the impact energy of $p_1 = 20$ MPa and $\sigma = 0.025$ is less than that of $p_1 = 15$ MPa and $\sigma = 0.014$ at high threshold level $F_{th} > 110$ N, even though the upstream pressure is larger. This fact means that the pulse height distribution can be changed by the upstream pressure and the cavitation number. Namely, the cavitating jet can simulate the several cavitating conditions. This is a great advantage of new ASTM standard G134 compared with the previous ASTM standard G32.

Maximum erosion rate

Figure 4 illustrate the mass loss with exposure time to the cavitating jet for tested materials at $p_1 = 20$ MPa and $\sigma = 0.014$. The mass loss increased gradually at an initial stage of the erosion. The mass loss rate, which was defined divergent of mass loss with the time, increased with the time, then decreased for all materials. The maximum

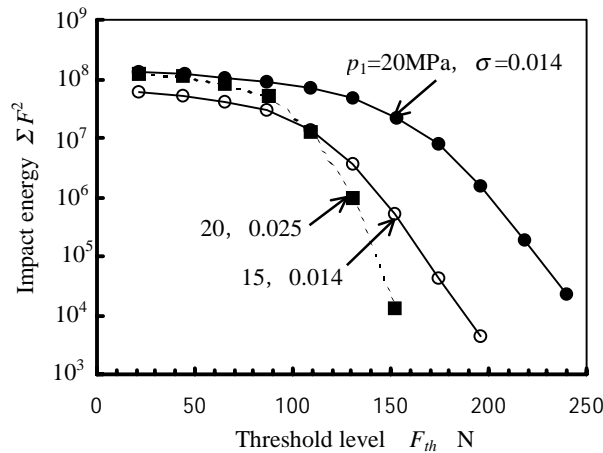

Figure 3: Impact energy changing with threshold level for different cavitating conditions

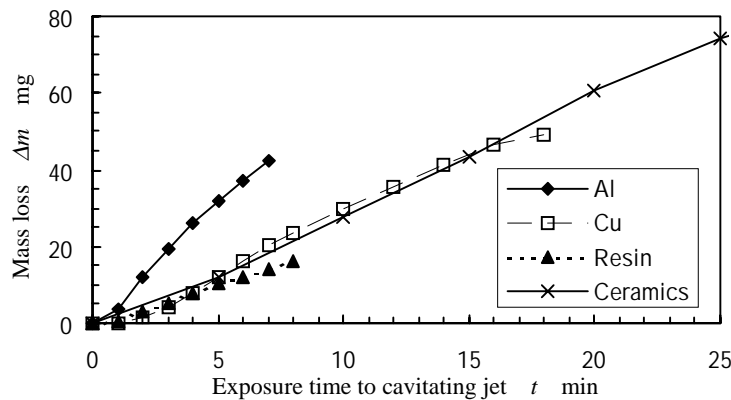

Figure 4: Mass loss of tested materials with exposure time to cavitating jet ($p_1 = 20$ MPa, $\sigma = 0.014$)

Table 2 Maximum erosion rate (Unite : mg/min)

Condition		Materials			
σ	p_1 MPa	Aluminum	Copper	Resin	Ceramics
0.014	15	3.31	1.38	0.96	1.33
0.014	20	6.55	2.96	2.05	3.03
0.025	20	4.56	1.98	0.87	1.90

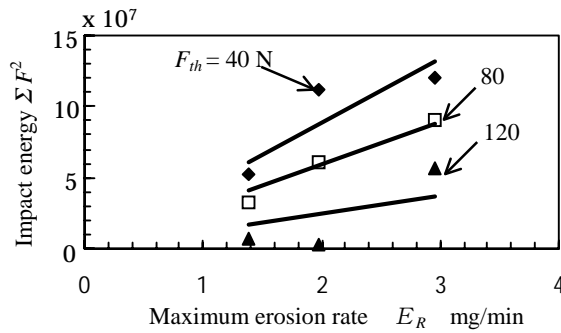

Figure 5: Relation between maximum erosion rate and impact energy changing with threshold level F_{th} (Cu)

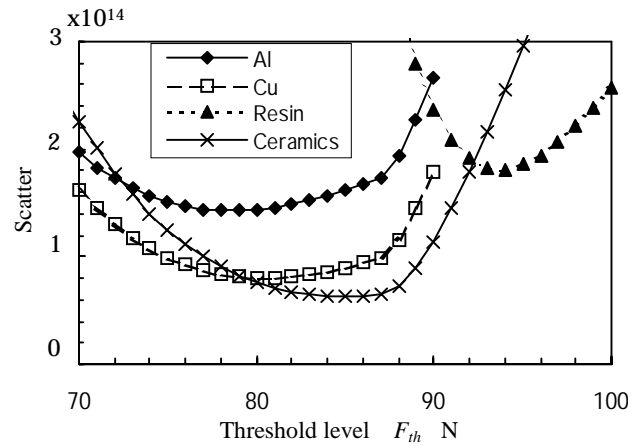

Figure 6: Optimum threshold level

erosion rate was the maximum of erosion rate with the time. The maximum erosion rate was used as a typical resistance of the material to cavitation erosion. The maximum erosion rate is identical for each tested materials.

Table 2 shows the peak erosion rate of all tested materials at three cavitating conditions. Now let's see the relative cavitation resistance of materials by comparing of the maximum erosion rate. For example, the acryl resin is 5.2 times stronger than the aluminum at $p_1 = 20$ MPa and $\sigma = 0.025$, however, the acryl resin is only 3.2 times stronger than the aluminum, at $p_1 = 20$ MPa and $\sigma = 0.014$. Namely, the relative cavitation resistance is varied about 60%, and it changing with the cavitating condition. In the next section, the reason why the difference was produced was discussed.

Threshold level of cavitation impact related to erosion

The cavitation impact, which is larger than certain threshold level, can affect material. When the optimum threshold level was chosen, the line, which revealed the relation between the erosion rate and the energy of the cavitation impact, shows good correlation. However, if the threshold level was too small or too large, the relation between the erosion rate and the energy of the cavitation impact should be scatter widely. Figure 5 shows the relation between the maximum erosion rate of copper and the impact energy changing with the threshold level F_{th} .

Table 3 Threshold level of material for tested materials (Unite : N)

Al	Cu	Resin	Ceramics
79	80	94	85

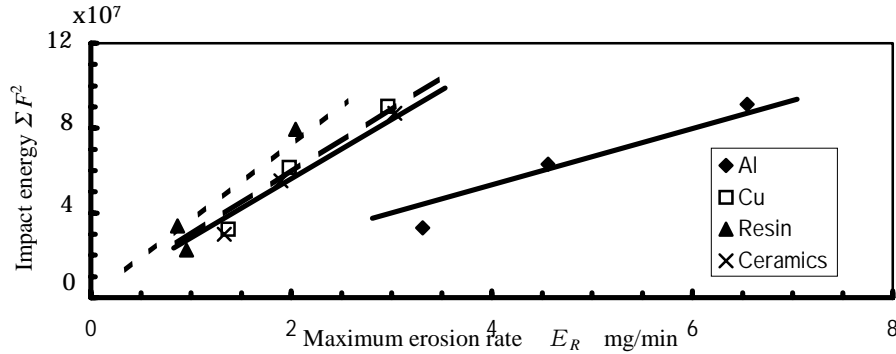

Fig. 7 Relation between maximum erosion rate and impact energy

At $F_{th} = 80$ N, the relation is on the straight line. However, the relation was scatter widely at $F_{th} = 40$ N and 80 N. Thus, it can be said that the optimum threshold level of copper is about 80N.

The scatter between the experimental data and the assumed line should be a minimum at an optimum threshold level changing with the threshold level. Figure 6 illustrates the scatter between the assumed line and the experimental data changing with the threshold level for all tested materials. For all material, the scatter has a minimum at the certain threshold level, which is the threshold level of the material. Table 3 shows the threshold level for tested materials. The threshold level was identical for each material. The threshold level of the acryl resin is rather larger than the other materials. In case of the acryl resin, the rather large cavitation attacks were absorbed by the elastic deform of the acryl resin. This will be the reason why the threshold level of the acryl resin is rather larger than the other materials.

Figure 7 shows the relation between the maximum erosion rate and the impact energy by using the threshold level for each materials. For all materials, the maximum erosion rate was proportional to the impact energy measured by PVDF transducer. The scatter band was less than 20%. It can be concluded that the erosion rate was estimated by considering the threshold level of materials. The threshold level of materials and the pulse height distribution were not considered, the relative resistance to cavitation erosion of materials is varied widely. The correlated line of the maximum erosion rate and the impact energy was identical for materials. The slope of the line shows a kind of the calibration constant to predict the erosion rate from the energy of the impact measured by the PVDF transducer. In case of the acryl resin, the threshold level of cavitation impact which relates the erosion of the acryl resin is large. Namely, the acryl resin can resist to the rather large cavitation impact. However, the erosion of the acryl resin develops very rapidly at the condition to takes place the erosion.

4 Prediction Method of Cavitation Erosion

Figure 8 illustrates a schematic diagram of prediction method of cavitation erosion by means of the erosion test and the cavitation impact measurement by using a cavitating jet apparatus.

Prediction method to estimate cavitation erosion in hydraulic machinery as follows;

(i) Maximum erosion rate: Maximum erosion rate of tested material should be examined at least two cavitating conditions by using a cavitating jet apparatus.

(ii) Cavitation impact energy at erosion test condition: The cavitation impact was measured by means of PVDF transducer and the impact energy should be calculated at the same cavitating condition of the erosion test. The cavitation impact measurement was required only one time for each cavitating condition.

(iii) Threshold level of material: Plot the scatter between the assumed line, which shows the proportional relation between the impact energy and the experimental maximum erosion rate changing with the threshold level. The threshold level of material was the threshold level where the scatter has a minimum value.

(iv) Relation between impact energy and maximum erosion rate: Obtain the calibration constant of the erosion

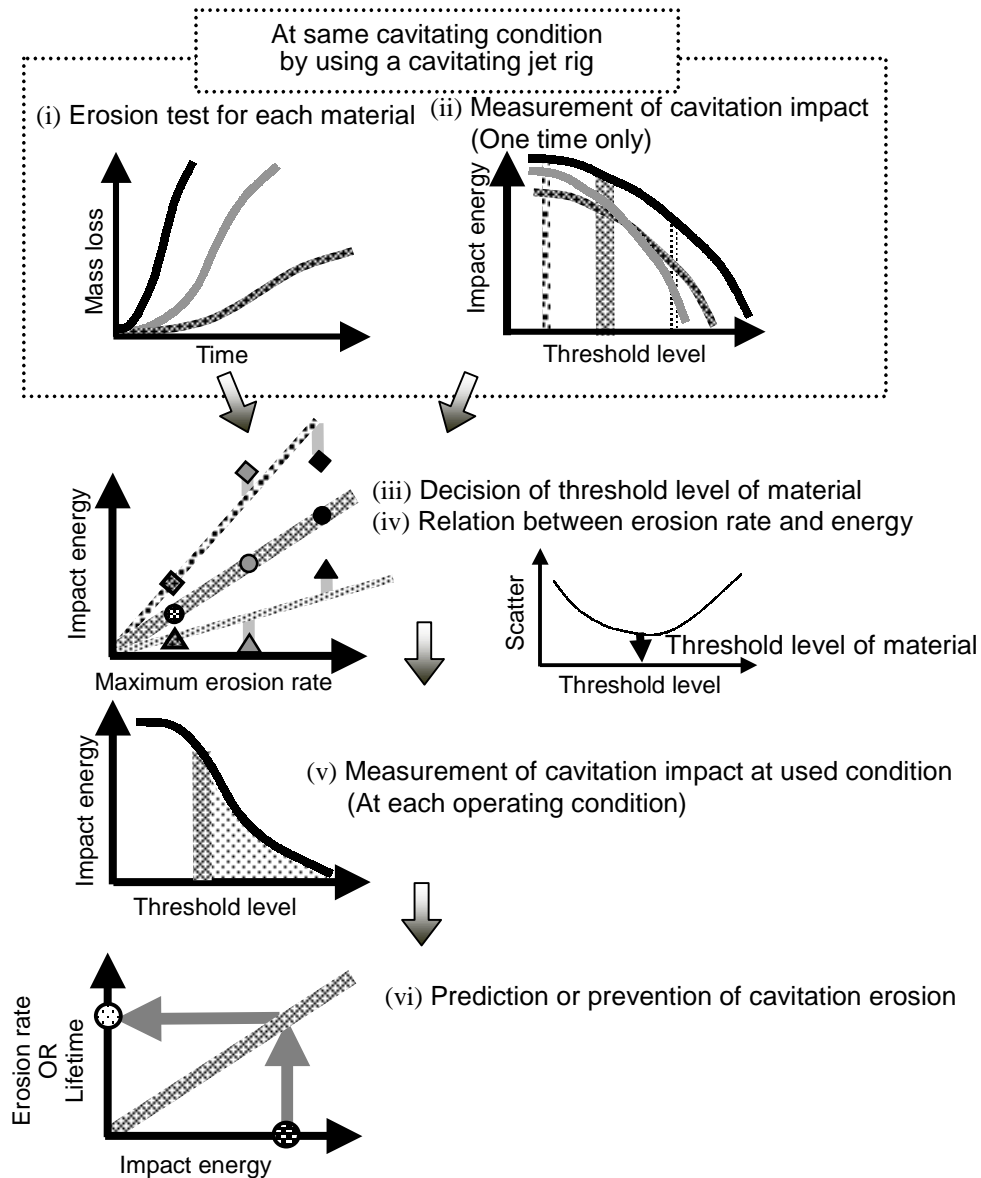

Figure 8: Schematic diagram to predict cavitation erosion by means of erosion test and measurement of cavitation impacts

rate. The calibration constant is obtained from the maximum erosion rate divided by the energy, which is larger than the above threshold level of material.

(v) Measurement of cavitation impact energy at operating condition: Measure the energy of the cavitation impact in hydraulic machinery by using a PVDF transducer.

(vi) Prediction or prevention of cavitation erosion: The erosion rate can be estimated by the calibration constant multiplied by the energy, which is larger than the above threshold level of material, measured by PVDF transducer in hydraulic machinery. In order to prevent cavitation erosion completely, the material whose threshold level is larger than the maximum cavitation impact at the operating condition.

5 Conclusions

In order to establish a prediction method of cavitation erosion quantitatively, the measurement of cavitation impact by PVDF transducer and the erosion test were carried out by using a cavitating jet apparatus. Tested

materials were pure aluminum, pure copper, acryl resin and ceramics. The main results are summarized as follows:

- (1) In order to predict the cavitation erosion rate, "threshold level of material" is very important parameter. The threshold level of the material means that the cavitation impact whose impact is larger than the threshold level is related to the cavitation erosion of the material. The threshold level of material is identical parameter of material.
- (2) The impact energy by means of the PVDF transducer was proportional to the maximum erosion rate of tested materials, i.e., pure aluminum, pure copper, acryl resin and ceramics, when the threshold level of the materials was considered.
- (3) A cavitating jet can simulate the several cavitating conditions.
- (4) A prediction method of cavitation erosion rate in hydraulic machinery by means of the erosion test and the cavitation impact measurement by using a cavitating jet was proposed.

References

- Arndt, R.E.A., Ellis, C.R. and Paul, S. 1995 Preliminary Investigation of the Use of Air Injection to Mitigate Cavitation Erosion. *Journal of Fluids Engineering, Trans. ASME*, Vol.117, pp.498-504.
- ASTM Designation G32-92 1997 Standard Test Method for Cavitation Erosion Using Vibratory Apparatus. *Annual Book of ASTM Standards*, Vol.03.02, pp. 103-116, 1997.
- ASTM Designation G134-95 1997 Standard Test Method for Erosion of Solid Materials by a Cavitating Liquid Jet. *Annual Book of ASTM Standards*, Vol.03.02, pp. 537-548, 1997.
- Hoam, N.T. 1994 Development et validation d'une methode analytique de prevision de l'erosion de cavitation. *Ph D thesis, L'Institut National Polytechnique de Grenoble*.
- Jones, I. R. and Edwards, D. N. 1960 An Experimental Study of the Forces Generated by the Collapse of Transient Cavities in Water. *Journal of Fluid Mechanics*, Vol.7, pp. 596-609.
- Lecoffre, Y. 1995 Cavitation Erosion, Hydrodynamic Scaling Laws, Practical Method of Long Term Damage Prediction. *Proc. International Symposium on Cavitation*, pp. 249-256.
- Momma, T. and Lichtarowicz, A. 1994 A New Calibration Method for Dynamically Loaded Transducers. *Proc. Fluid Measurement and Instrumentation*, FED-Vol.183, pp. 103-107.
- Okada, T., Iwai, Y. and Awazu, K. 1989 A Study of Cavitation Bubble Collapse Pressure and Erosion Pit. *Wear*, Vol.133, pp. 219-232.
- Okada, T., Iwai, Y., Ishimaru, H. and Maekawa, N. 1994 Measurement and Evaluation of Cavitation Bubble Collapse Pressures. *JSME International Journal*, Ser. A, Vol. 37, pp. 37-42.
- Soyama, H., Lichtarowicz, A., Momma, T. and Williams, E.J. 1998 A New Calibration Method for Dynamically Loaded Transducers and Its Application to Cavitation Impact Measurement. *Journal of Fluids Engineering, Trans. ASME*, Vol.120, pp. 712-718.